

Digital input module

Short guide

1. Overview

MV210-202 and MV210-204 are extension modules with 20 digital inputs.

The module has two Ethernet ports for connection within the daisy chain scheme. If the module fails or the power is turned off, the data transmission will be fed directly from port 1 to port 2 without disconnecting.

The full User Guide is available on the device page at www.akytec.de.

2. Environmental conditions

Table 1 Operating conditions

Condition	Permissible range
Ambient temperature	-40...+55 °C
Transportation and storage	
Relative humidity	up to 95 % (at +35 °C, non-condensing)
Attitude	up to 2000 m ASL
IP code	IP20
Vibration / shock resistance	conforms to IEC 61131-2
EMC emission / immunity	conforms to IEC 61131-2

3. Specifications

Table 2 General specifications

Parameter	Value
	Electrical
Power supply	24 (10 ... 48) V DC
Power consumption	6 W at 24 V DC
Polarity protection	Yes
Appliance class	II
	Interfaces
Data transfer	Double Ethernet 10/100 Mbps
Protocols	Modbus TCP, MQTT SNMP, NTP
Configuration interface	USB 2.0 (MicroUSB) Ethernet 10/100 Mbps
	Digital inputs of MV210-202
Inputs number	20
Input signal	contact sensor (requires external 24 V power supply) NPN / PNP transistor AB encoder
Functions	logical level detection high frequency pulses counter (only DI1-DI8) frequency measurement (only DI1-DI8) encoder signal processing (up to 3 encoders)

Parameter	Value
Pulse length, min. (DI1-8)	5 µs (up to 100 kHz)
Pulse length, min. (DI9-20)	1 ms (up to 400 Hz)
LOW level (current), max.	1.2 mA
HIGH level (current), max.	5.5 mA
LOW level (voltage range)	0.0...6.1 V
HIGH level (voltage range)	8.8...30.0 V
Digital inputs of MV210-204	
Inputs number	20
Input signal	Switch contact (potential free) NPN transistor
Functions	Pulse counter Logical level detection
Pulse length, min.	1 ms (f ≤ 400 Hz)
Input lines (loop) resistance, min.	100 Ω
Flash-memory (log file storage)	
File size, max.	2 kB
Number of log files, max.	1000
Logging interval, min.	10 s
Real time clock	
Accuracy	±3 s/day at +25 °C ±10 s/day at -40 °C
Backup battery	CR2032
Mechanical	
Dimensions	42 × 124 × 83 mm
Weight	approx. 260 g

4. Installation and connection

Before installation make sure there is enough free space for connecting the module and placing the wires. The module is mounted on a DIN rail or on a vertical surface using screws.

Installation of external connections is carried out by a wire with a cross section of not more than 0.75 mm².

For stranded wires, use end sleeves.

After installation, put the wires into the cable channel of the module housing and close the cover.

If necessary, in order to remove the terminal blocks of the module, loosen the two screws at the corners of the terminal blocks.



CAUTION

Connection and maintenance is performed only when the module power and the power to all devices connected to it is turned off.

Table 3 Network parameters

Parameter	Description	Default value
IP address	IPv4 Internet Protocol address	192.168.1.99
Subnet mask	IP address recognition area in the subnet	255.255.255.0
Gateway	IP address of the gateway	192.168.1.1
DNS server 1	Primary DNS server	77.88.8.8
DNS server 2	Secondary DNS server	8.88.8.8

5. Connecting diagrams

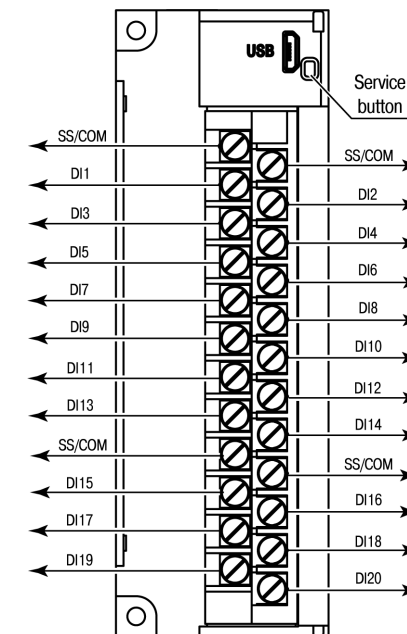


Fig. 1 Terminal block layout

Table 4 Terminal assignments

Marking	Description
DI1...DI20	Input terminals
COM (MV210-204)	Common input power supply point
SS (MV210-202)	

The service button performs the following functions:

- Factory settings restore
- IP-address assignment

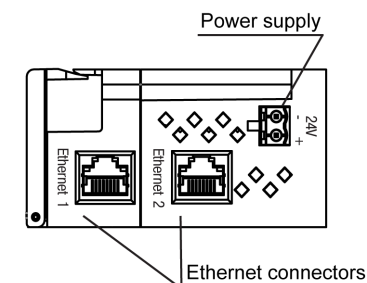


Fig. 2 Device connectors

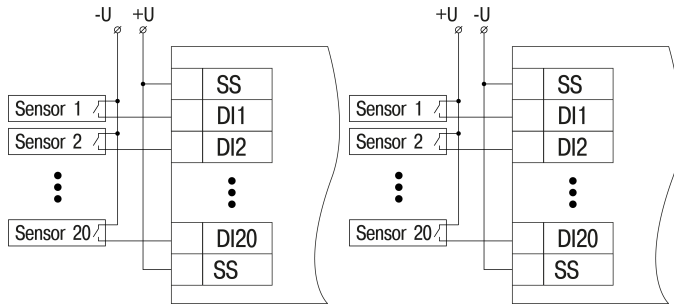
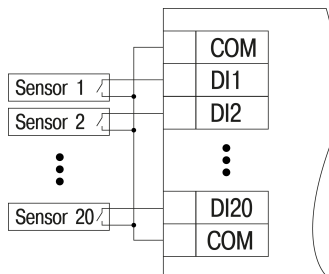
Fig. 3 Contact sensor wiring
(MV210-202) – option 1Fig. 4 Contact sensor wiring
(MV210-202) – option 2

Fig. 5 Contact sensor wiring (MV210-204)

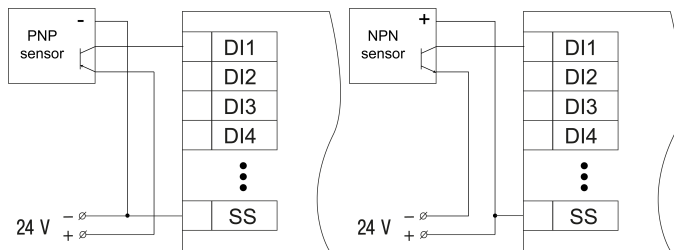
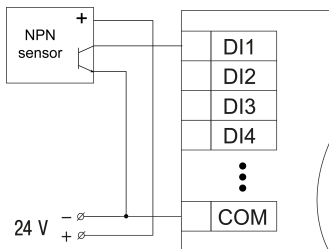
Fig. 6 PNP sensor wiring
(MV210-202)Fig. 7 NPN sensor wiring
(MV210-202)

Fig. 8 NPN sensor wiring (MV210-204)

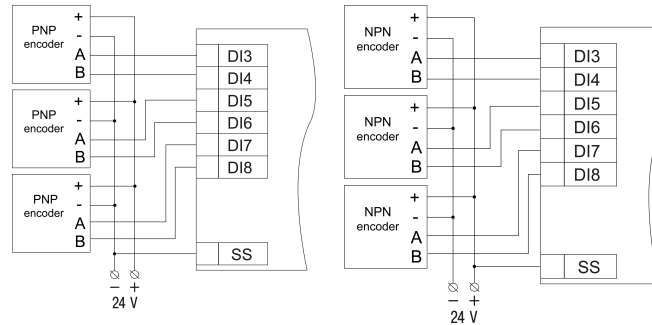


Fig. 9 PNP encoder wiring

Fig. 10 NPN encoder wiring

6. Settings

The module is configured via the Modbus TCP protocol or in the akYtec Tool Pro program via the USB interface (see User Guide). If the module is connected to the USB port, the main module power supply is not required.

7. Indication

Table 5 LEDs

LED	Color	LED State	Description
⏻	green	Off	Power off
		On	Power on
Eth 1	green	Off	Not connected
		Flashing	Data transfer over Ethernet 1 interface
Eth 2	green	Off	Not connected
		Flashing	Data transfer over Ethernet 2 interface
⚠	red	Off	No errors
		On	Program / configuration error
		Flashing (0.1 s / 2 s)	Low battery
		Flashing (0.1 s / 0.5 s)	No requests from master. Safe state activated
		Flashing (0.9 s / 1 s)	Hardware peripherals error (Flash, RTC, Ethernet Switch)
Input LEDs (20)	green	Off	LOW on the input
		On	HIGH on the input